



SPREAD-ALL MFG. CO.

2237 MARSHALLTOWN BLVD. • MARSHALLTOWN, IOWA 50158
PHONE: (641) 753-5601 • TOLL FREE: 1-800-383-5601 • FAX: (641) 752-9748
WWW.SPREAD-ALLMFG.NET



OPERATING MANUAL

CENTRIFUGAL FAN

SAFETY PRACTICES

1. Have a qualified electrician install your fan for proper grounding. A proper ground is necessary for protection against electrical shock and lightning strikes. The use of Ground Fault Circuit Interrupter (GFCI) is suggested on all outside electrical wiring to reduce potential for electrical shock.
2. No electrical maintenance checks should be done if power is "ON."
3. Fan guards should be kept in place during the operation of the fan.
4. The intake of the fan should be kept clear for proper air flow. When a shipment is received you should carefully check while unpacking and before installing the unit for possible damage or shortage of parts. In case of problems in shipping, such as shortage or damage, you should file a claim with the carrier.

• INSTALLATION INSTRUCTIONS •

1. SOLID BASE

Bad vibrations are hard on the motor. They cause a wearing process on the motor bearings that may limit the life of the motor. It is therefore necessary to take time and effort to put your fan on a solid base. A concrete slab is ideal as a base. If the slab is not level, wooden spacers may be used under the fan legs. If the fan unit is not level the binding of the unit will deform the fan housing and will cause future problems.

2. INSTALLATION DATA

Careful planning should be made for installing the fan unit. The fan unit should be elevated as high as the grain bin itself. The fan unit should either be connected to the grain bin or at a distance for proper connection to the transition.

3. ELECTRICAL

A certified electrician must do all electrical service, and the installation must be done according to "Part 1" of the National Electrical Code (USA). A circuit breaker box with fuse protection must be installed for the fan unit. The fuse requirements are sized for 25% overload capacity. These fuses are for the protection of the operator.

Any questions should be referred to an electrician for both service needs and for installation.

Ground fan according to the above electrical code.

PRE-START INSTRUCTIONS

1. Check by rotating the fan blade to make sure it does not hit or rub against the housing.
2. Check ALL fastening devices for tightness and check for proper clearance. Any loose fasteners should be tightened.
3. Make certain that the fan and switch are well grounded.
4. Give the fan a trial run before installing it. Check to see that the fan blade rotates properly and that the air is flowing in the proper direction.

OPERATION & MAINTENANCE

Spread-All fans use standard NEMA frame motors. Any authorized service stations of any motor manufacturer can supply the replacement parts. These motors are designed for crop drying and are protected by built-in thermal overloads. Single phase motors with 1725 RPM may have problems during the initial starting surge. The amperage surge of the initial start is usually five times the rating on the motor and the total voltage drop should not be below 190 volts on the starting surge, and no lower than NEMA specified 10% of the line voltage during the starting surge; there is a good possibility that it may burn capacitors out. If the line voltage remains low during the operation, the motor will probably overheat and a shutoff or burn out is likely to take place.

- **SPREAD-ALL FANS SHOULD BE RUN 30 MINUTES EVERY 3 WEEKS TO ELIMINATE ANY DAMAGING MOISTURE BUILD-UP IN THE MOTOR.** •

• FEATURES & FAN DATA •



FEATURES

- 5HP-25HP
- Single phase or three phase
- Galvanized
- Quiet
- 1725 rpm
- Magnetic starter
- Weather-resistant guard
- Completely factory assembled and test run before shipment

CFM AT INCH OF STATIC PRESSURE

MODEL	FAN SIZE	HP	0	1"	2"	3"	4"	5"	6"	7"
SA-CF50	22"	5	9,200	8,400	7,600	7,000	6,100	4,500		
SA-CF75	24"	7.5	11,400	10,600	9,800	9,200	8,300	7,400	5,000	
SA-CF10	27"	10	13,000	12,250	11,500	11,000	10,500	9,500	9,000	7,600
SA-CF15	27"	15	18,000	17,500	16,500	15,750	15,000	14,000	12,250	11,000
SA-CF20	27"	20	20,500	19,500	18,500	17,750	16,500	15,500	14,000	12,000
SA-CF25	30"	25	25,000	24,000	23,000	22,000	21,000	20,000	19,000	18,000

MOTOR AMPS

FAN MODEL	1PH 230V	3PH 230V	3PH 460V
SA-CF50	23	13.4	6.7
SA-CF75	30	18.8	9.4
SA-CF10	38	24.4	12.2
SA-CF15	66	36.2	18.1
SA-CF20	-	48	24
SA-CF25	-	60	30

• CENTRIFUGAL FAN DIMENSIONS •

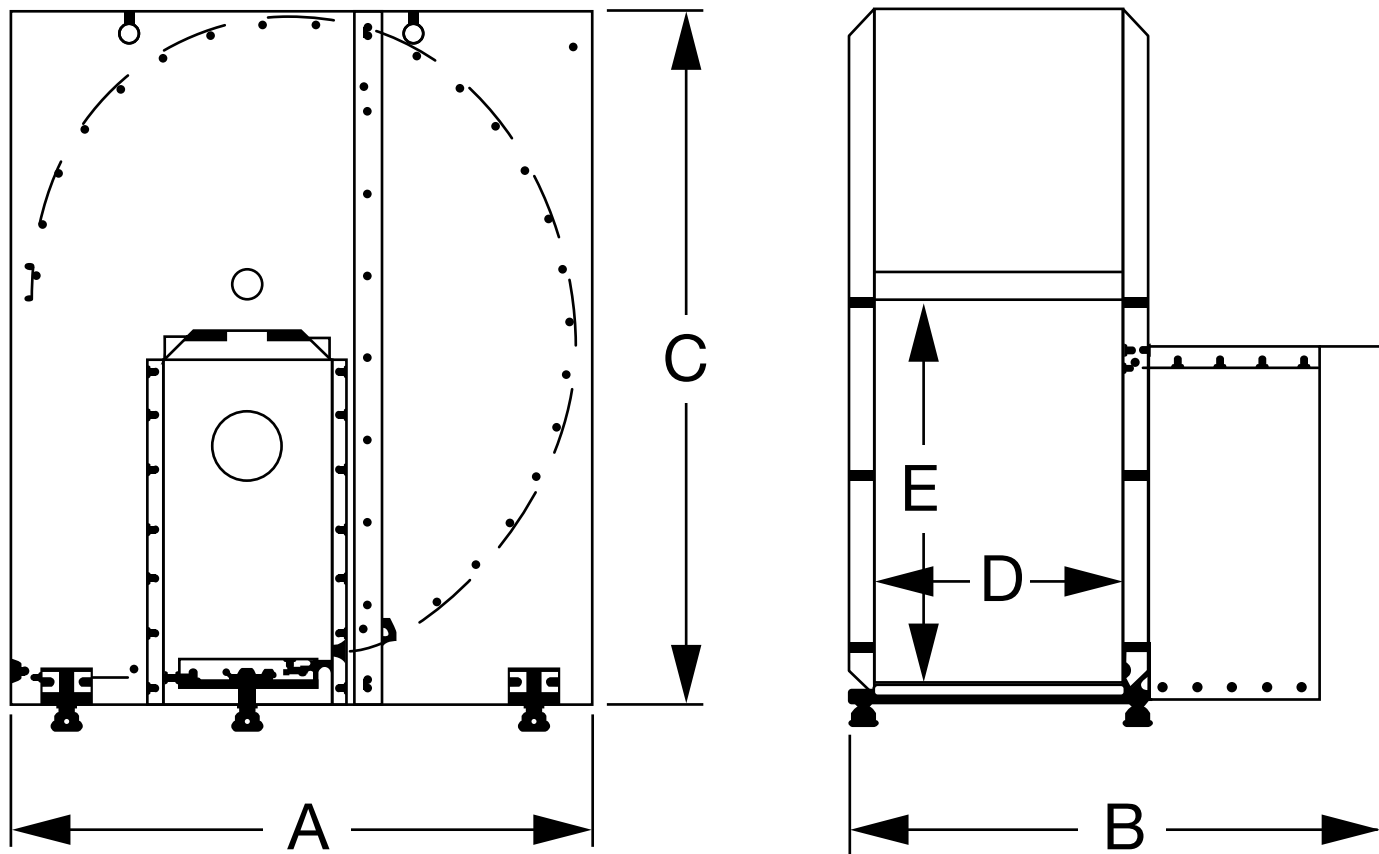

1725 RPM CENTRIFUGAL FAN DIMENSIONS - INCHES

	A	B	C	D	E
5 HP	38	32 1/2	43 1/4	15	20
7.5 HP	38	34	43 1/4	16 1/2	20
10 HP	42 1/4	36	51	16	26 1/2
15 HP	42 1/4	41	51	19	26 3/4
20 HP	42 1/4	42	51	20 1/4	26
25 HP	46 1/4	46	53 3/4	21	26 1/2

* These dimensions should be used as estimates only and not as a guarantee. Because of new ideas and ways to improve products, Spread-All reserves the right to make changes that may not be reflected in this chart. We will, however, try our best to update them in a timely and cost-effective manner.

15HP 230 VOLT - 1 PH

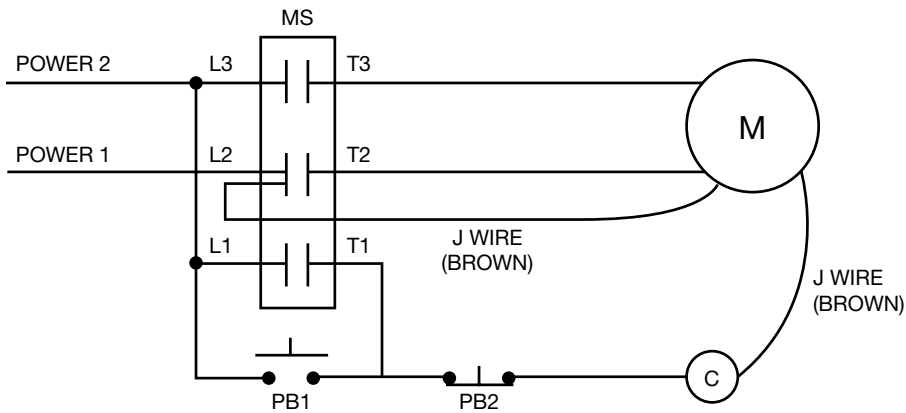

Control circuit voltages are the same as that of the incoming power supply.

5-7.5-10HP • 230 VOLT - 1 PH • Manual Reset

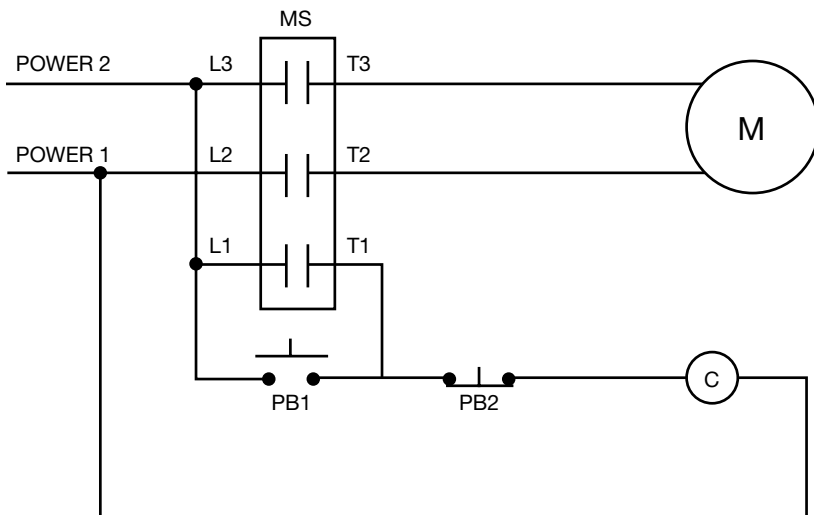

Control circuit voltages are the same as that of the incoming power supply.

230/460 VOLT - 3 PH

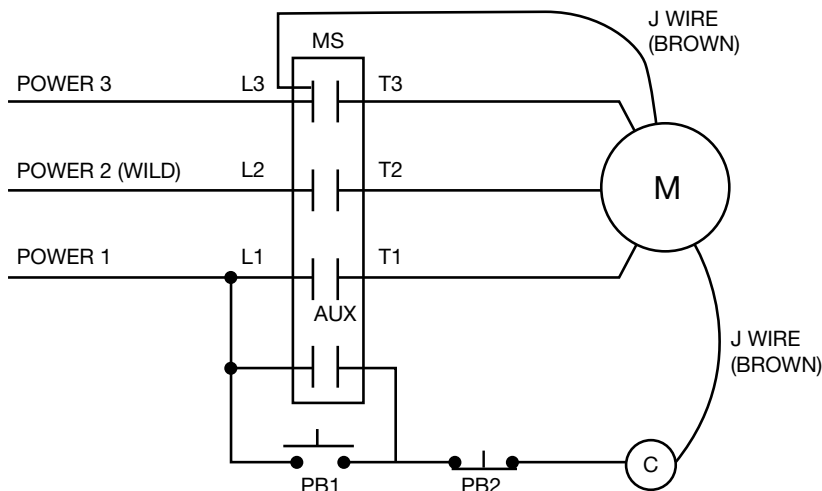

Control circuit voltages are the same as that of the incoming power supply.

MAIL GUARANTEE CARD TODAY

(MAIL WITHIN 10 DAYS OF PURCHASE OR GUARANTEE IS VOID)

Owner _____
Street or Route _____
City _____ State _____ ZIP/Zone _____
Dealer's Name _____ Model# _____
Address _____ Serial# _____
Date of Purchase _____

SPREAD-ALL equipment is guaranteed against defective material and workmanship for a period of one year from the date of sale to the original purchaser. We will repair or replace defective parts upon inspection and direction by our service department. No returns for credit allowed. We will not handle warranty on electric motors. Motor warranties will be handled by the motor manufacturers and their repair stations. Spread-All does not cover labor costs or milage charges on warranty or non-warranty work.

We assume no responsibility for any damage incurred in transit or for any other abuses, or incorrect application — nor for any attempted repairs by others without our written authorization. Sender must receive written permission from our factory before returning equipment. All shipping charges to and from the factory on defective units will be assumed by the customer.

Manufacturer shall only be liable under this guarantee if the product is used in the proper manner as specified in the enclosed instructions.

Manufacturer specifically disavows any other representation, warranty or liability related to the condition or use of this product.

The warranties contained herein are the only warranties made by the manufacturer, and no other warranties, express or implied, are given on this product.

Any warranty contained herein shall not apply to any product which shall have been repaired or altered outside the manufacturer's facilities or in any way so as, in the manufacturer's judgment, to affect its stability or reliability, or which has been subject to misuse, negligence or accident. Warranties shall not apply to any product which shall not have been operated in accordance with the printed instructions or shall have been operated beyond the rate of capacity of the product.

**Please complete and mail
within 10 days of purchase to:**

**SPREAD-ALL MFG. CO.
2237 MARSHALLTOWN BLVD.
MARSHALLTOWN, IOWA 50158-9892**



SPREAD-ALL MFG. CO.

2237 MARSHALLTOWN BLVD. • MARSHALLTOWN, IOWA 50158
PHONE: (641) 753-5601 • TOLL FREE: 1-800-383-5601 • FAX: (641) 752-9748
WWW.SPREAD-ALLMFG.NET

GRAIN STORAGE EQUIPMENT



SA-105 & SA-106 SPINNING GRAVITY SPREADER

- Gravity Spreader designed to help keep fines out of center of smaller bins
- Has strong hanger straps (and a leveling strap)
- Capacity:
SA-105: 3000-5000 Bu./Hr.
SA-106: 6000-9000 Bu./Hr.
(Depending on grain and moisture)

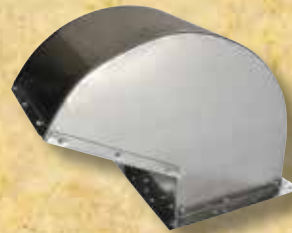

ROOF VENTS

- Models Available | 70 & 90 degree
- Heavy, easily detachable angle base
 - Lock seam joints
 - Birdproof screen
 - 100% galvanized to withstand years of weather conditions
 - Symmetrically punched holes make one-person installation a breeze
 - Double edges add strength
 - Pivot Screen Available



SA-98 GALVANIZED GRAVITY SPREADER

- To help keep fines from center of small bins
- Light weight 18#
(Comes unassembled in box)



SPREAD-ALL TRANSITIONS FEATURE:

- All galvanized steel
- All welded construction
- Completely assembled
- Transitions have access doors
- SA-82 (shown).

COMPLETE OFFERING OF AERATION FANS



FEATURES:

- Galvanized
- Models SA-12075 and SA-14100 feature 115 volt, single phase electric motors with plug cords wired
- Standard leg stands and carrying handles
- Weather-resistant guard
- Completely factory assembled and test run before shipment
- Magnetic contactor mounted in a weatherproof enclosure on 24" & 28" fans
- Reversible application to pull air down through the grain, or to direct the air flow up through the grain by turning the fan around and reversing guard
- Either the intake or the discharge ends may be mounted to an air duct, metal transition or a flat wall bin
- These fans are designed for quiet, efficient aeration with a minimum of maintenance and operating cost
- Models available 12" to 28" ...
So you can get just the right fan to do the job right

COMPLETE OFFERING OF GRAIN SPREADERS

**OUR MOST
POPULAR
MODEL!**



- SA-93
SPREAD-ALL SPECIAL**
For 6" & 8" auger
- Without reversing switch
 - Capacity: Up to 3000 Bu./Hr. (Depending on grain and moisture)
 - Powered: oil bath gear case
 - Motor: 1/2 HP 115V
 - Weight: 85 lbs
 - Bin diameters 18' to 30'
 - Vary the spread by tilting pan



- SA-97
E-3 COMPACT**
For 10" auger
- With reversing switch
 - Capacity: 3000 to 5000 Bu./Hr. (Depending on grain and moisture)
 - Powered: oil bath gear case
 - Motor: 1/2 HP 115V
 - Weight: 85 lbs
 - Bin diameters: 18' to 36'
 - Reversible switch to change from narrow to wide spread



- SA-94
E-2 COMPACT**
For 6" & 8" auger
- With reversing switch
 - Capacity: Up to 3000 Bu./Hr. (Depending on grain and moisture)
 - Powered: oil bath gear case
 - Motor: 1/2 HP 115V
 - Weight: 85 lbs
 - Bin diameters 18' to 36'
 - Reversible switch to change from narrow to wide spread



- SA-97HS
E-3 HIGH SPEED**
For 10" auger
- With reversing switch
 - Capacity: 3000 to 5000 Bu./Hr. (Depending on grain and moisture)
 - Powered: oil bath gear case
 - Motor: 1 HP 115V
 - Weight: 100 lbs
 - Bin diameters: 42' +
 - Reversible switch to change from narrow to wide spread



- SA-95HS
E-2 HIGH SPEED**
For 6" & 8" auger
- With reversing switch
 - Capacity: Up to 3000 Bu./Hr. (Depending on grain & moisture)
 - Powered: oil bath gear case
 - Motor: 1/2 HP 115V
 - Weight: 85 lbs
 - Bin diameters: 42' +
 - Reversible switch to change from narrow to wide spread



- SA-103
E-6**
For 13" auger
- With reversing switch
 - Capacity: 6000 to 9000 Bu./Hr. (Depending on grain and moisture)
 - Powered: oil bath gear case
 - Motor: 1 HP 115V
 - Weight: 100 lbs
 - Bin diameters: 18' to 36'
 - Reversible switch to change from narrow to wide spread



- SA-96
E-3 COMPACT**
For 10" auger
- Without reversing switch
 - Capacity: 3000 to 5000 Bu./Hr. (Depending on grain and moisture)
 - Powered: oil bath gear case
 - Motor: 1/2 HP 115V
 - Weight: 85 lbs
 - Bin diameters: 18' to 36'
 - Vary the spread by tilting pan



- SA-104HS
E-6 HIGH SPEED**
For 13" auger
- With reversing switch
 - Capacity: 6000 to 9000 Bu./Hr. (Depending on grain and moisture)
 - Powered: oil bath gear case
 - Motor: 1 HP 115V
 - Weight: 100 lbs
 - Bin diameters: 42' +
 - Reversible switch to change from narrow to wide spread